



**Installation Manual v1.0:
204-901-4248:
Pulse Flow Exhaust Manifolds
2001-2004.5 LB7 Duramax 6.6L
EGR Equipped Vehicles**



Figure 1 - Kit Contents

Please read all instructions before installation.

1. Before beginning installation, please check to make sure all of the parts pictured in Figure 1 are inside the ATS Pulse Flow Manifold kit. A complete corresponding list of components can be found on page 10.
2. Raise and support the vehicle. Installation will require removal of the front tires and wheelhouse liners.
3. Remove the intake manifold cover clamp at the resonator. Loosen the intake manifold cover bolt. Remove the intake manifold cover.

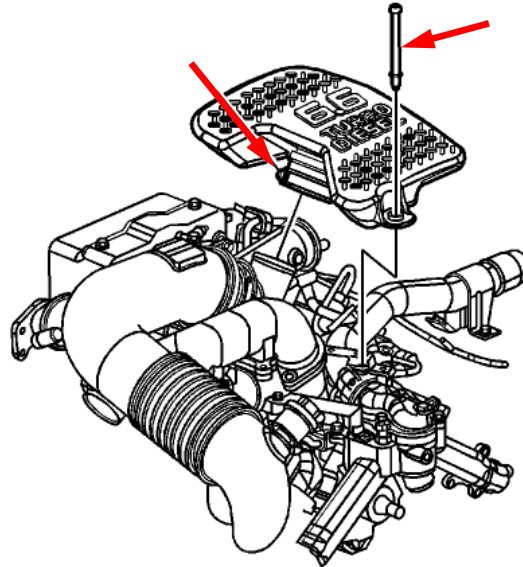

Figure 2 - Intake Manifold Cover Removal

4. To swap the driver side manifold, first loosen the charge pipe clamp at the turbocharger shown in *Figure 3*.

NOTE: Do not use a screwdriver or other tool to pry the boot loose. The boot can be torn or damaged. Loosen the boot by twisting.

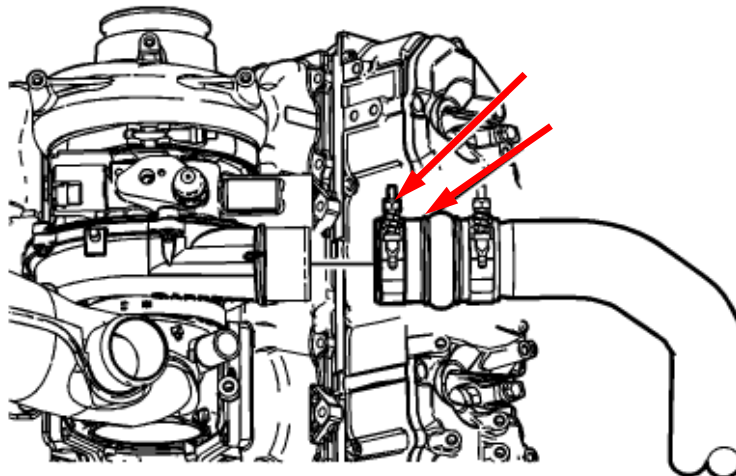

Figure 3 - Charge Pipe Removal

5. Remove the intercooler charge pipe boot from the turbo.
6. Cover/seal the turbo opening to prevent debris from falling in the turbo.
7. Remove the driver side front tire. This will allow better access to the wheelhouse liner.
8. Remove the driver side wheelhouse liner.
9. Working through the wheelhouse, loosen the clamp holding the charge pipe to the intercooler. Remove the charge pipe from the vehicle and set it aside.

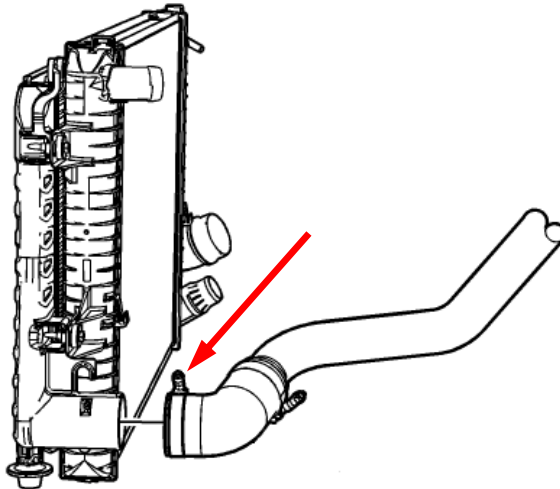

Figure 4 - Charge Pipe Removal

10. Cover the intercooler inlet port to prevent debris from entering the intercooler.
11. Mark and disconnect the steering shaft.

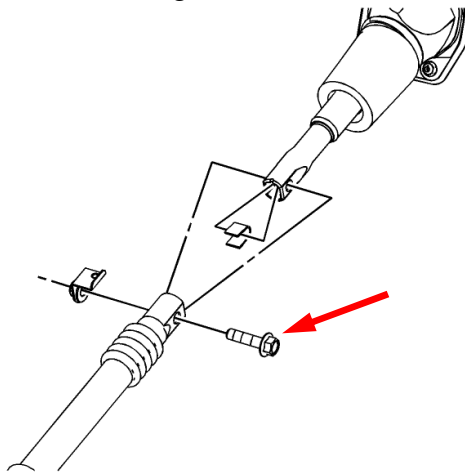

Figure 5 - Steering Shaft Disconnect

12. To access the up-pipe to turbo pedestal bolts, it may be necessary to disconnect and possibly remove the exhaust downpipe.

13. Remove the up-pipe heat shield bolts. Reposition the heat shield to the side in order to access the up-pipe to exhaust manifold bolts.

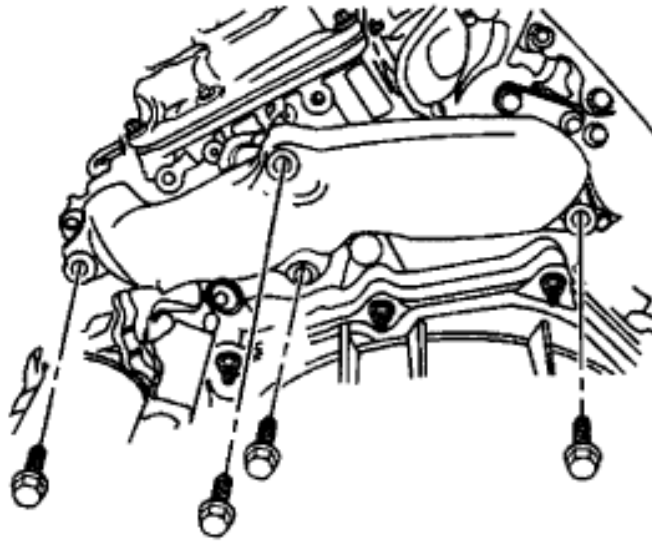

Figure 6 - Heat Shield Removal

14. Remove the up-pipe to exhaust manifold bolts and up-pipe to turbo pedestal bolts. Remove the up-pipe and heat shield. Discard the gaskets.

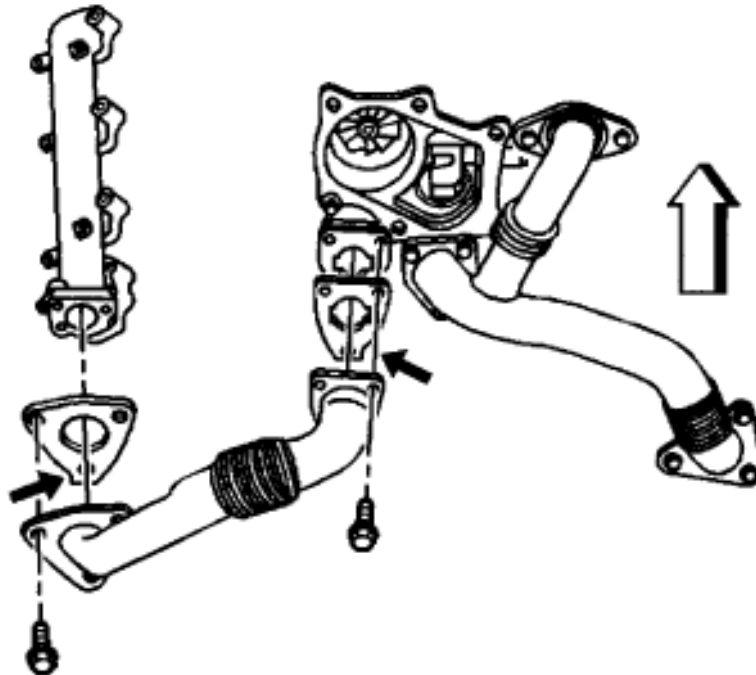

Figure 7 - Up-Pipe Removal

15. Through the wheelhouse, remove the exhaust manifold heat shield bolts and remove the heat shield.

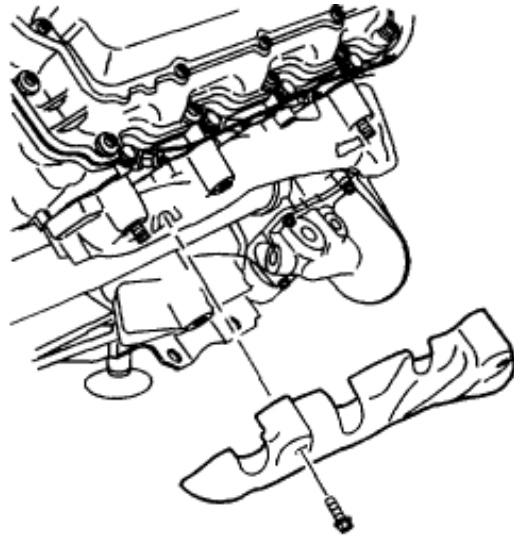

Figure 8 - Manifold Heat Shield Removal

16. Remove the exhaust manifold bolts and nuts.

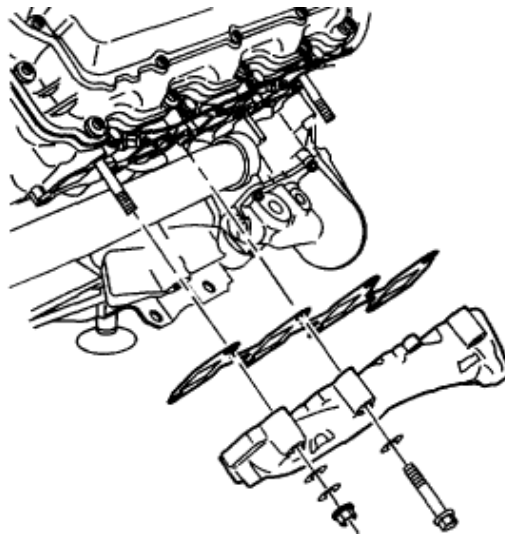

Figure 9 - Manifold Removal

17. Remove the exhaust manifold by sliding it over the front and rear studs, out the bottom past the oil filter.
18. Replace the exhaust manifold gasket. Replacement gaskets can be purchased from ATS or at any GM dealership using part number 98002804.
19. Remove the stud in the back of the head. This will be replaced by the long M10 bolts supplied in the kit.

20. Slide the exhaust manifold gasket over the remaining factory stud. Replace the factory manifold with the new ATS Pulse Flow Exhaust Manifold.

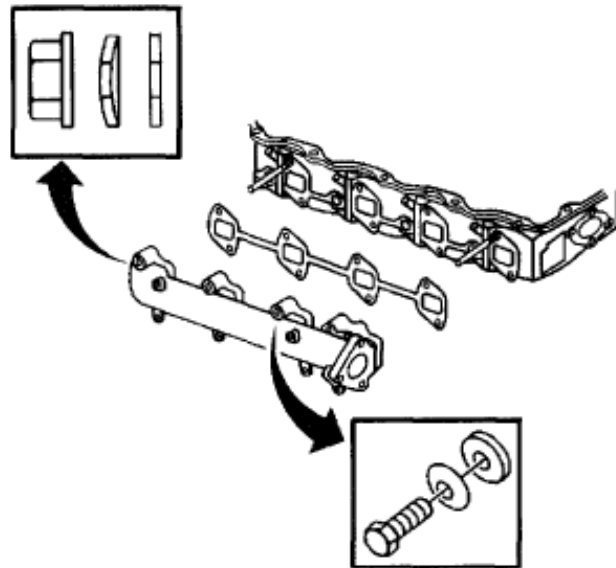

Figure 10 - Manifold Installation

21. Thread in bolts and nut hand tight. Torque in the sequence shown below first to **25 ft-lbs**. Re-torque the hardware to **35 ft-lbs** following the same sequence.

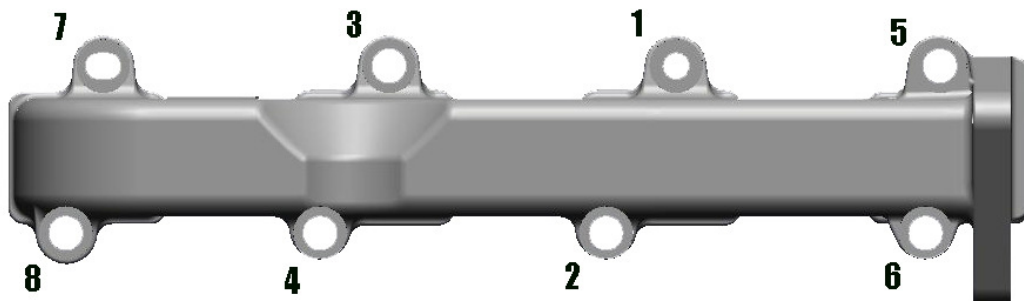

Figure 11 - Manifold Torque Sequence

22. Install the new up-pipe using the factory hardware and gaskets included in the kit. Torque the bolts to **39 ft-lbs**.

NOTE: Use 3 of the socket head cap screws to bolt the up-pipe to the manifold.

23. Reconnect the steering shaft.
 24. Reinstall the charge pipe and torque the clamps to **70 in-lbs**.
 25. Replace the wheelhouse liner and tire.

26. Torque wheel nuts to factory specs.
27. To install the passenger side Pulse Flow manifold, first remove the wheelhouse liner (removing the tire can help).
28. Remove the exhaust manifold heat shield bolts and heat shield.
29. Remove the driver side up-pipe. Discard the gaskets.

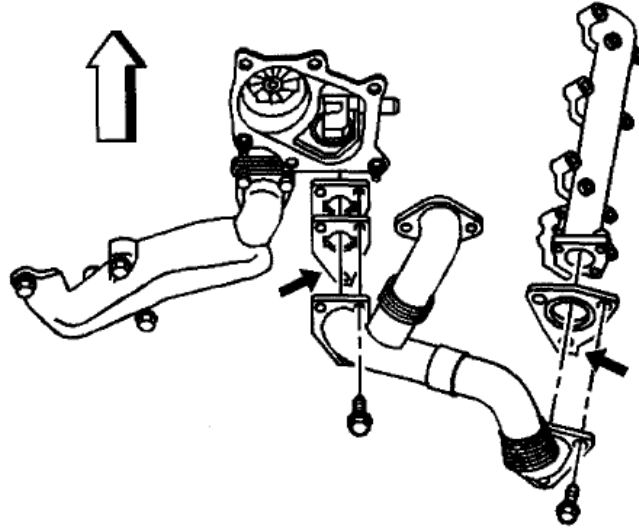

Figure 12 - Up-Pipe Removal

30. Remove the bolts and nuts from the remaining manifold.
31. Remove the exhaust manifold.

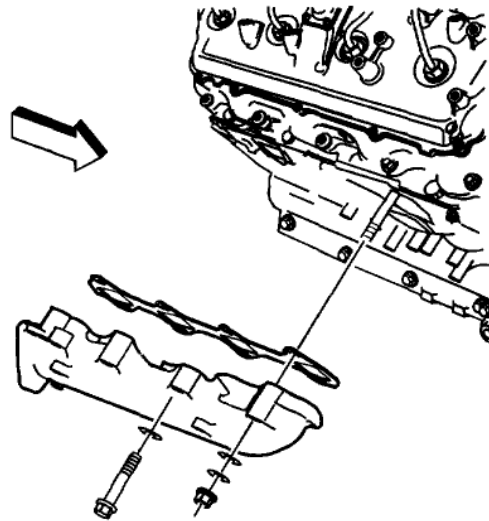

Figure 13 - Manifold Removal

32. Remove the bolt for the oil level indicator tube bracket in order to remove the exhaust manifold gasket.
33. Replace the exhaust manifold gasket. Replacement gaskets can be purchased from ATS or at any GM dealership using part number 98002804.

34. Remove the factory stud in the back of the head, this will be replaced by the long bolts included in the kit.
35. Slide the exhaust manifold gasket over the remaining factory stud.
36. Replace the factory manifold with the new ATS Pulse Flow Exhaust Manifold.

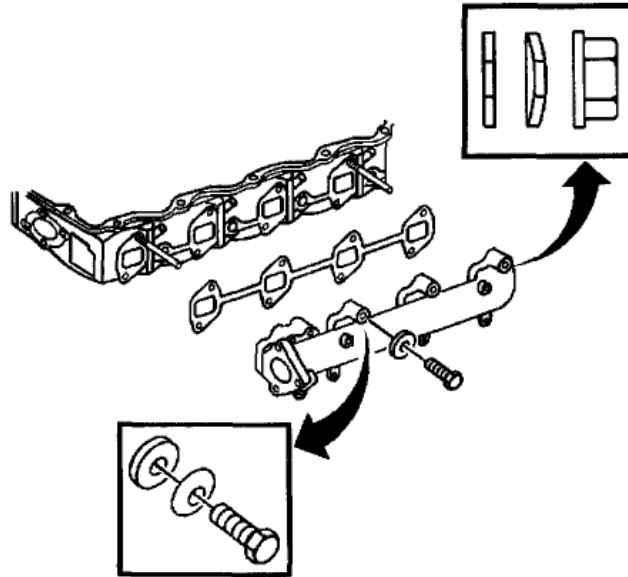

Figure 14 - Manifold Installation

37. Thread in bolts and nut hand tight. Torque in the sequence shown below first to **25 ft-lbs**. Re-torque the hardware to **35 ft-lbs** following the same sequence.

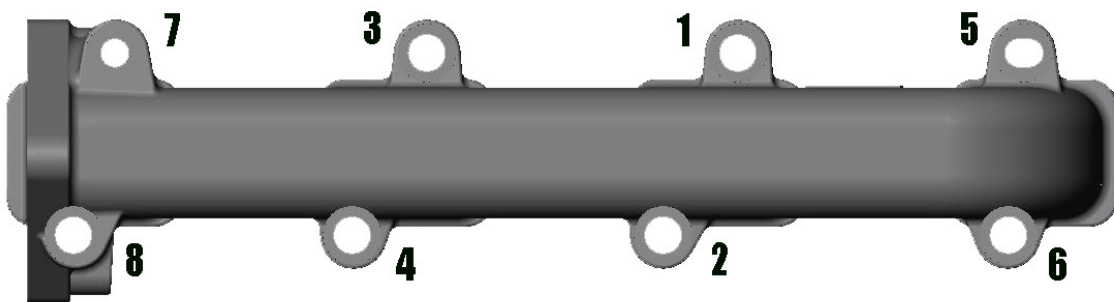

Figure 15 - Manifold Torque Sequence

38. Replace the bolt for the oil level indicator tube bracket.
39. Install the new up-pipe using the factory hardware and gaskets included in the kit. Torque the bolts to **39 ft-lbs**.

NOTE: Use 3 of the socket head cap screws to bolt the up-pipe to the manifold.

40. Reinstall the downpipe.
41. Reinstall the wheelhouse liner and tire if removed.

42. Reinstall the intake manifold cover.
43. Start the truck and check for leaks. If no leaks are present, installation is complete.

Have Any Questions?

Thank you for purchasing the Pulse Flow Exhaust Manifolds.. Please call or e-mail our Technical Service Department, 8:00am to 5:30pm Mountain Standard Time, Monday through Friday.

Contact Information

Toll Free: 800-949-6002
Local: 303-431-7973
Fax: 303-431-0135
Website: www.ATSDiesel.com
Email: info@ATSDiesel.com

We strive to make our instructions as clear and complete as possible. To achieve this, our instructions are under constant construction. We encourage you to visit our website to check for the most up-to-date manuals and diagrams as well as other information. If you have any suggestions as to how we can improve this installation manual, let us know at <mailto:Suggestions@ATSDiesel.com>.

Bill of Materials

1. ATS Pulse Flow Exhaust Manifold, Driver Side 204-102-4248
2. ATS Pulse Flow Exhaust Manifold, Passenger Side 204-101-4248
3. Up-Pipe, Driver Side 204-106-4248
4. Up-Pipe, EGR Passenger Side 204-105-4248
5. (2) Gasket, Exhaust Manifold to Up-Pipe 97188685
6. (2) Gasket, Up-Pipe to Turbo Pedestal 97192618
7. Hardware Kit 204-001-4248
 - a. (4) M10-1.5 x 110mm Hex Cap Screw
 - b. (10) M10-1.5 x 60mm Cap Screw
 - c. (14) M10 Thick Flat Washer
 - d. (14) M10 Lock Washer
 - e. (6) M10-1.5 x 25mm Socket Head Cap Screws

Not Pictured:

8. Exhaust Manifold Instruction Manual 204-901-4248-INST
9. Gasket, Up-Pipe to EGR 97328807